

### SPECIFICATIONS

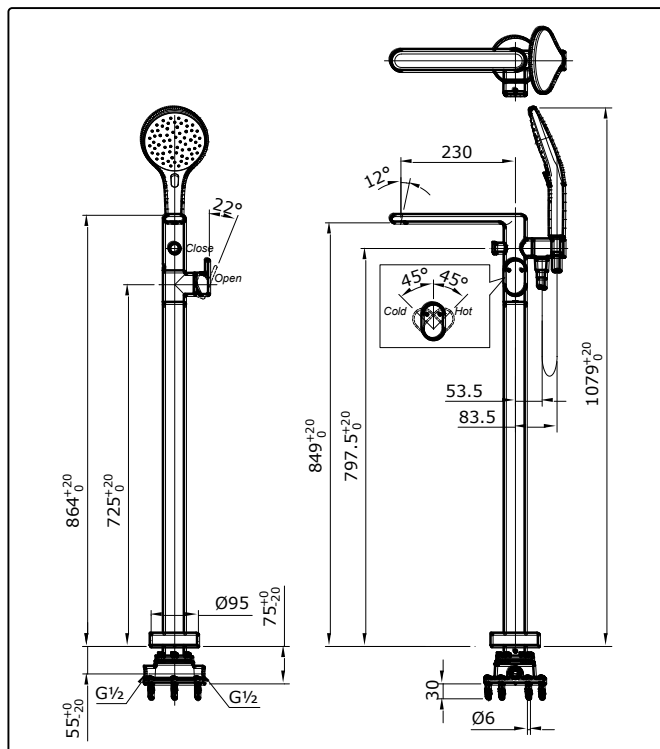

### OPERATING CONDITIONS

1. Water supply pressure : 0.05 ~ 0.75 MPa.
2. Ensure that water supply is clean ( No Sand, Dirt, Etc.).

### ATTENTION

1. Don't use abrasive cleaners or solvents on faucets and fittings.
2. As the product model is constantly updated, the actual product may not look the same as it shown in the diagram, but the basic installation principles are the same.

### MAINTENANCE

All Finishes : Clean the finish with mild soap and warm water. Wipe entire surface completely dry with clean soft cloth. Many cleaners may contain chemicals, such as ammonia, chlorine, toilet cleaner etc. which could adversely affect the finish and are not recommended for cleaning

### INSTALLATION

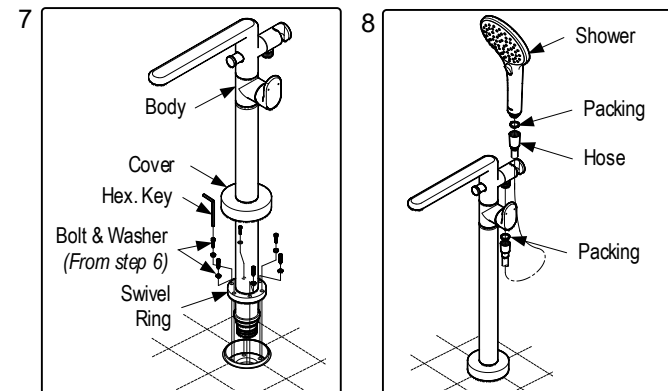
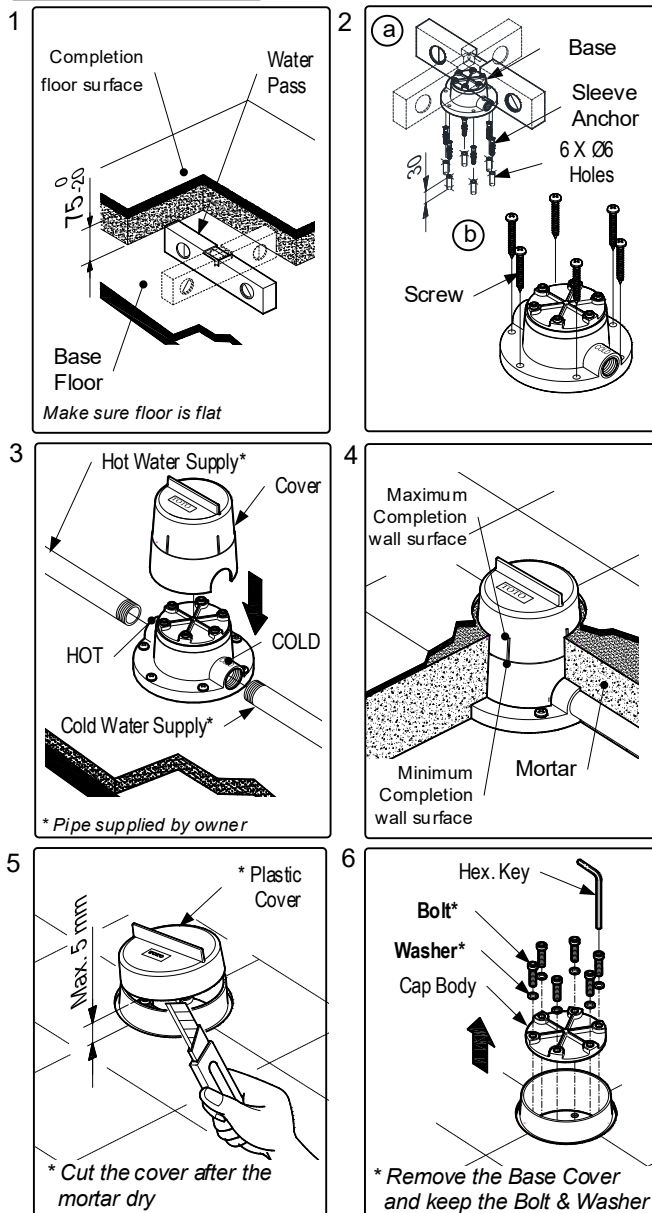

### TROUBLESHOOTING

| PROBLEM                     | CHECK POINT | SOLUSI         |
|-----------------------------|-------------|----------------|
| Flow rate unsatisfactory    | 1           | Remove & clean |
| Unsatisfactory spray        | 2           | Clean          |
| Water leaks around the hose | 3, 4        | Tighten        |
| Handle is loose             | 5           | Tighten        |

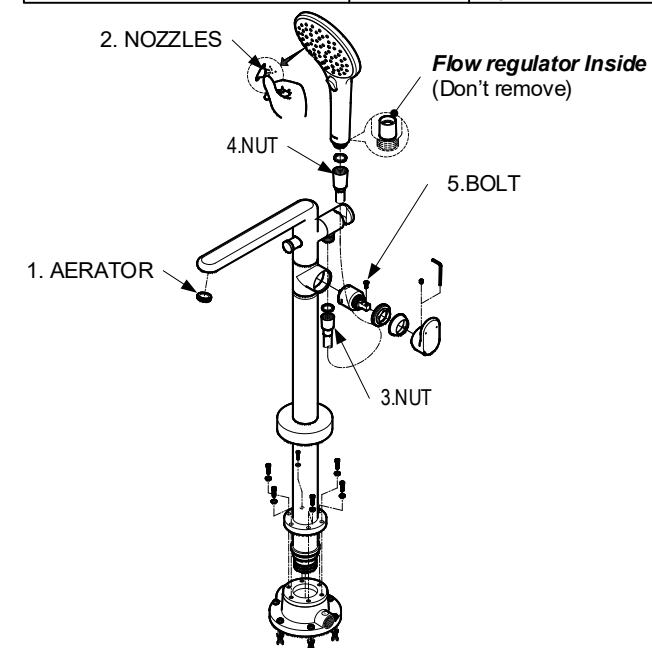

### SPESIFIKASI

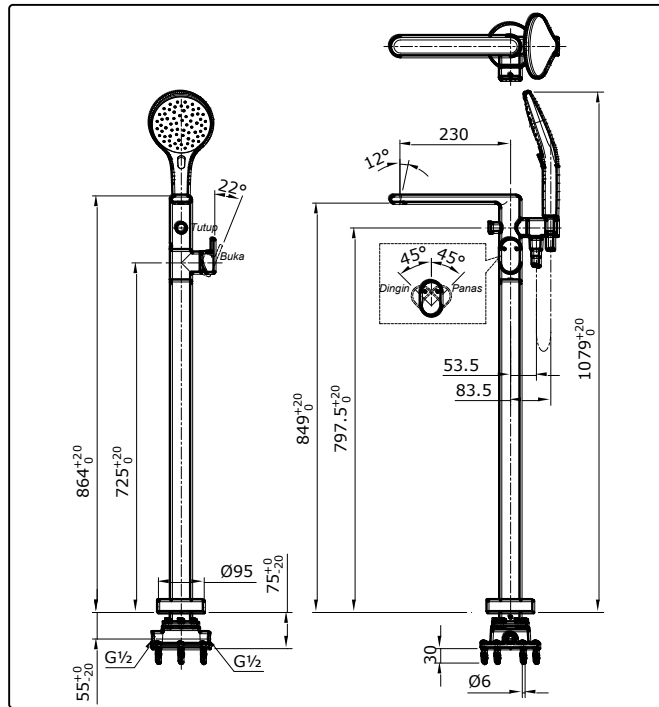

### KONDISI OPERASIONAL

1. Tekanan sumber air: 0.05 ~ 0.75 MPa.
2. Pastikan kondisi sumber air adalah bersih (tidak ada pasir, kotoran dan lain lain)

### PEMELIHARAAN

1. Jangan gunakan pembersih atau pelarut abrasif pada faucet dan fitting.
2. Karena model produk terus mengalami pembaharuan, aktual produk mungkin tidak sama dengan gambar, tapi prinsip dasar pemasangan adalah sama.

### PERHATIAN

Seluruh lapisan : Bersihkan lapisan akhir dengan sabun lembut dan air hangat. Lap seluruh permukaan hingga benar-benar kering dengan kain lembut yang bersih. Kebanyakan bahan pembersih mungkin mengandung bahan kimia, seperti amonia, klorin, pembersih toilet, dll. yang dapat mempengaruhi hasil akhir dan tidak disarankan untuk membersihkan

### PEMASANGAN

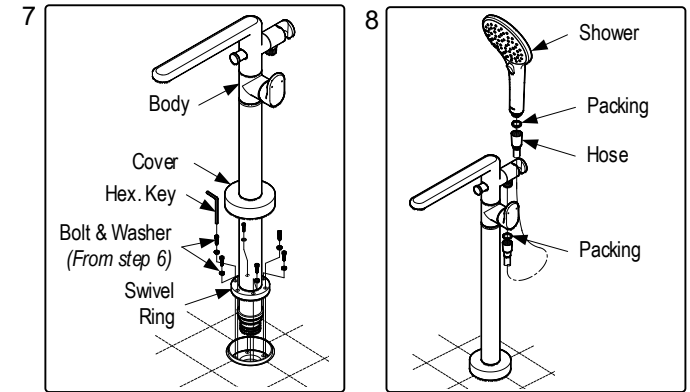
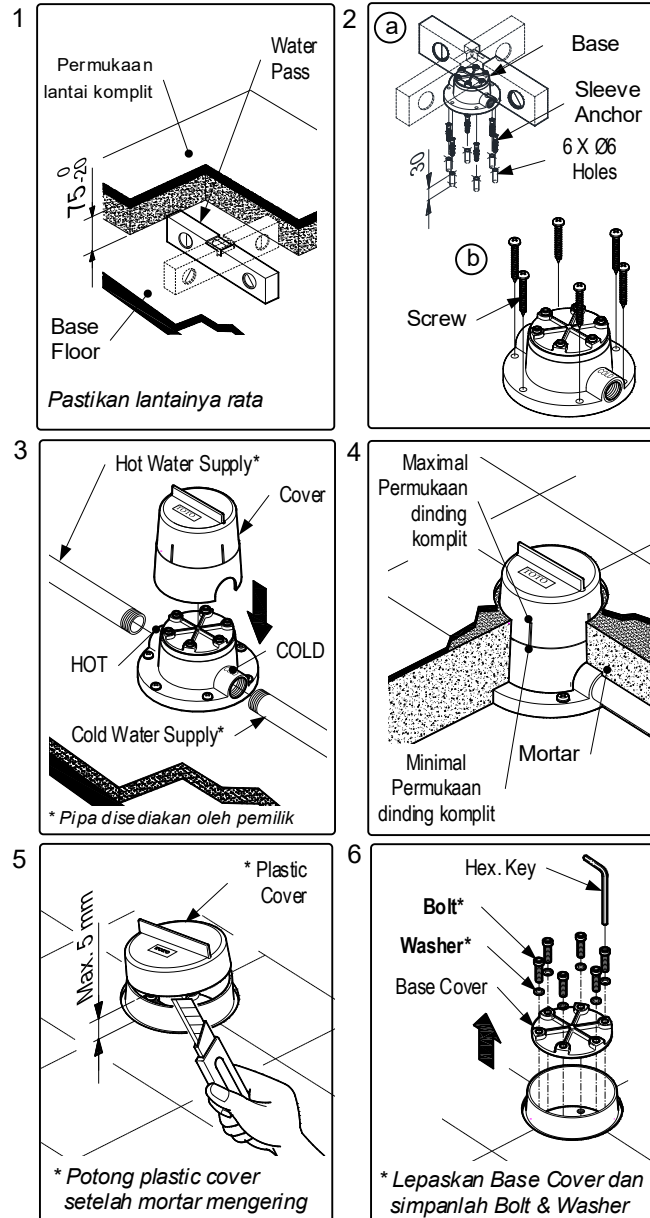

### PENYELESAIAN MASALAH

| MASALAH                  | POIN PERIKSA | SOLUSI           |
|--------------------------|--------------|------------------|
| Aliran tidak memuaskan   | 1            | Buka & bersihkan |
| Pancaran tidak memuaskan | 2            | Bersihkan        |
| Air bocor disekitar hose | 3, 4         | Kencangkan       |
| Handle longgar           | 5            | Kencangkan       |

