

SPECIFICATIONS

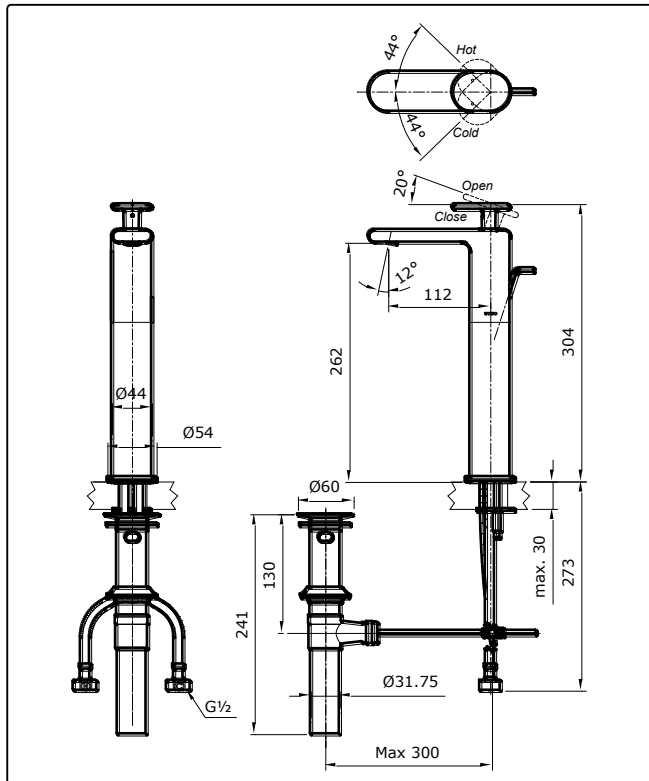

OPERATING CONDITIONS

1. Water supply pressure : 0.05 ~ 0.75 MPa.
2. Ensure that water supply is clean (No Sand, Dirt, Etc.).

ATTENTION

1. Don't use abrasive cleaners or solvents on faucets and fittings.
2. As the product model is constantly updated, the actual product may not look the same as it shown in the diagram, but the basic installation principles are the same.
3. When release the cartridge. Press the cartridge before turning the nut.

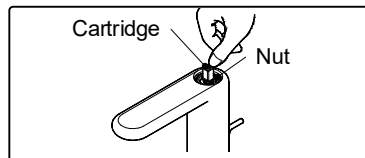

INSTALLATION

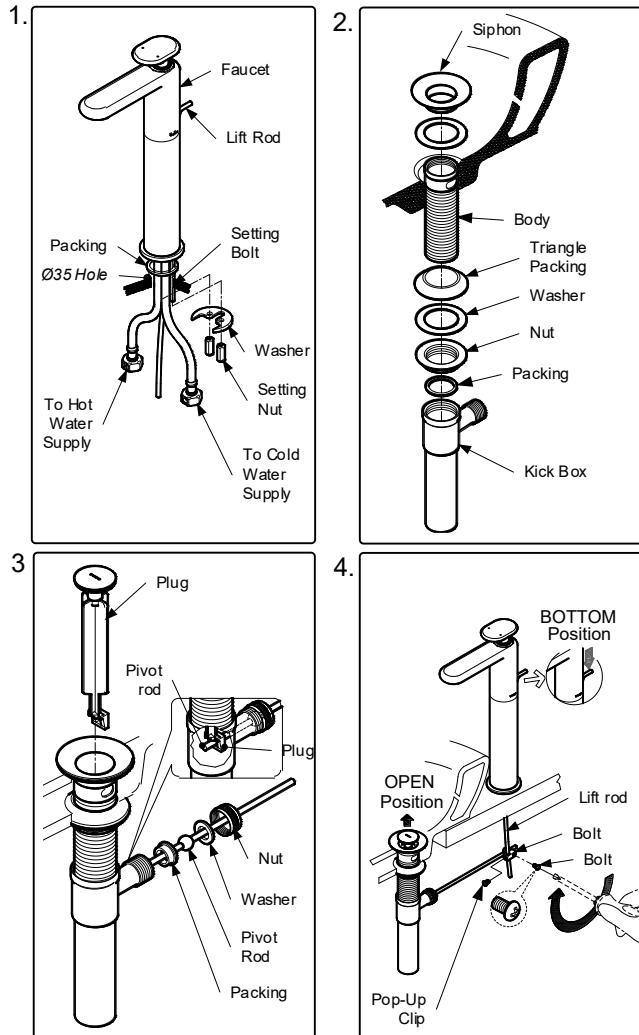

MAINTENANCE

All Finishes : Clean the finish with mild soap and warm water. Wipe entire surface completely dry with clean soft cloth. Many cleaners may contain chemicals, such as ammonia, chlorine, toilet cleaner etc. which could adversely affect the finish and are not recommended for cleaning

TROUBLESHOOTING

PROBLEM	CHECK POINT	SOLUTION
Flow rate unsatisfactory	1	Remove & clean
Water leaks around the handle	2	Tighten
Handle is loose	3	Tighten
Plug can not open and close	4	Tighten

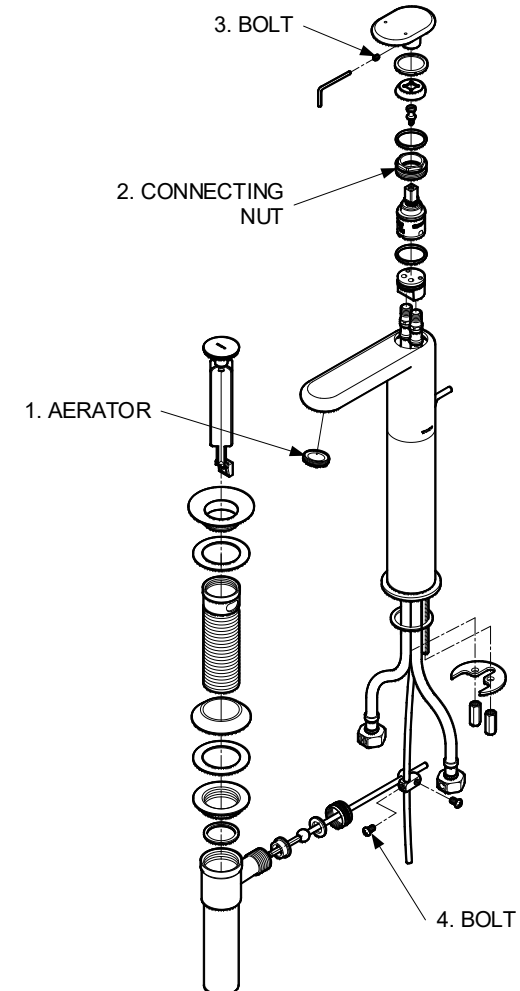

SPESIFIKASI

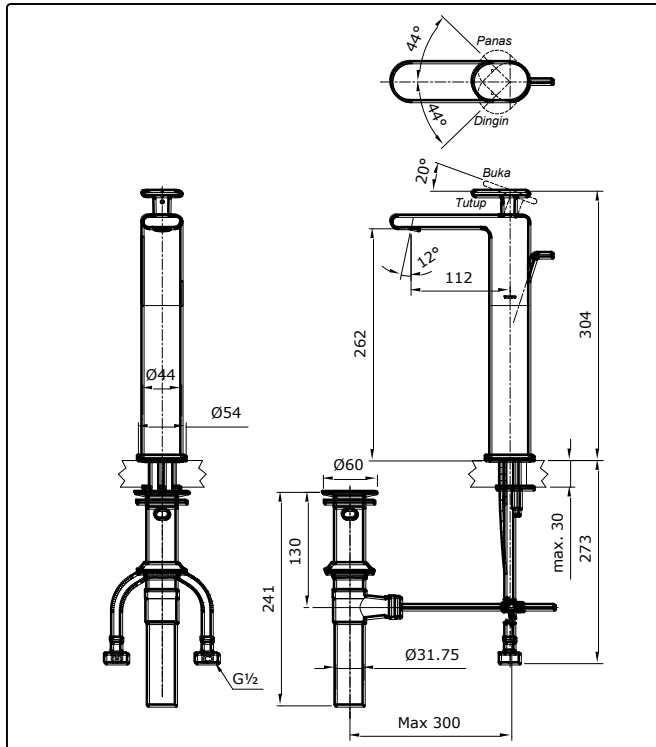

KONDISI OPERASIONAL

1. Tekanan sumber air: 0.05 ~ 0.75 MPa.
2. Pastikan kondisi sumber air adalah bersih (tidak ada pasir, kotoran dan lain lain)

PERHATIAN

1. Jangan gunakan pembersih atau pelarut abrasif pada faucet dan fitting.
2. Karena model produk terus mengalami pembaharuan, aktual produk mungkin tidak sama dengan gambar, tapi prinsip dasar pemasangan adalah sama.
3. Ketika melepaskan cartridge. Tekanlah cartridge sebelum memutar nut.

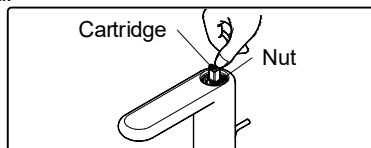

PEMASANGAN

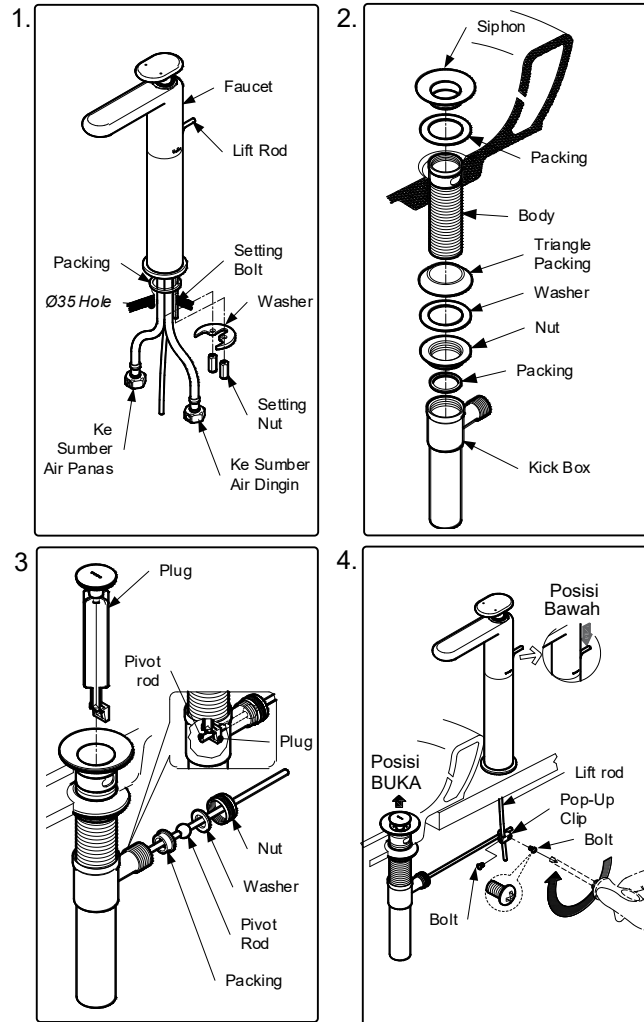

PEMELIHARAAN

Seluruh lapisan : Bersihkan lapisan akhir dengan sabun lembut dan air hangat. Lap seluruh permukaan hingga benar-benar kering dengan kain lembut yang bersih. Kebanyakan bahan pembersih mungkin mengandung bahan kimia, seperti amonia, klorin, pembersih toilet, dll. yang dapat mempengaruhi hasil akhir dan tidak disarankan untuk membersihkan

PENYELESAIAN MASALAH

MASALAH	POIN PERIKSA	SOLUSI
Aliran tidak memuaskan	1	Buka & bersihkan
Air bocor disekitar handle	2	Kencangkan
Handle longgar	3	Kencangkan
Plug tidak bisa dibuka dan ditutup	4	Kencangkan

